

PNEUMATIC CYLINDER ACTUATORS, SERIES B1

Metso's Neles double acting and spring return B1-Series piston type actuators are designed for use in both modulating control and on-off service. The series B1C and B1J are designed to ISO 5211/1 when Metso linkages are utilized. These actuators offer an extremely long cycle life and are well suited to operate almost any type of rotary valve.

When "stay put" is the requirement, the double acting B1C series is the choice. This series is available in several sizes with torque outputs from 40 Nm to 100 000 Nm (29.5 lbf ft to 73 756 lbf ft) for maximum supply pressure of 10 bar (145 psi).

If a failure mode is required, the spring return B1J series should be selected. This line offers a self-contained spring cartridge to provide failure in either the open or closed position. The spring return actuators are available with a mid-range spring for a 4 bar (58 psi) supply range, a lighter spring for lower supply pressure of 3 bar (44 psi) range and a stronger spring for a 5.5 bar (80 psi) range. These actuators offer torque outputs from 25 Nm to 12000 Nm (18,5 lbf ft to 8851 lbf ft) for maximum supply pressure of 8.5 bar (124 psi).

Adjustable travel stops

As with any Neles pneumatic/hydraulic actuator, adjustable travel stops are standard for both the open and closed positions. End of stroke turning angle range is 85° to 95°. Optional travel stops 0° to 90° are also available.

Wear resistant bearings

High quality bearings provide support on the upper and lower portions of the lever arm to reduce friction and expand the life of both the lever arm and the housing.

Corrosion resistance

The epoxy painted actuators have housings of rugged cast iron, with light-weight aluminum cylinders anodized for added corrosion resistance. Travel stops are stainless steel.

Self-contained spring cartridge

The springs in the B1J actuator are contained in a cartridge for added reliability and easy maintenance.

Spring to open or close capability

The standard spring return actuator on the ball valve can provide spring-to-close or spring-to-open operation simply by changing the mounting position by 90°. On a high performance butterfly valve, the standard unit offers spring-to-close operation. An optional B1JA model is available for spring-to-open requirements.

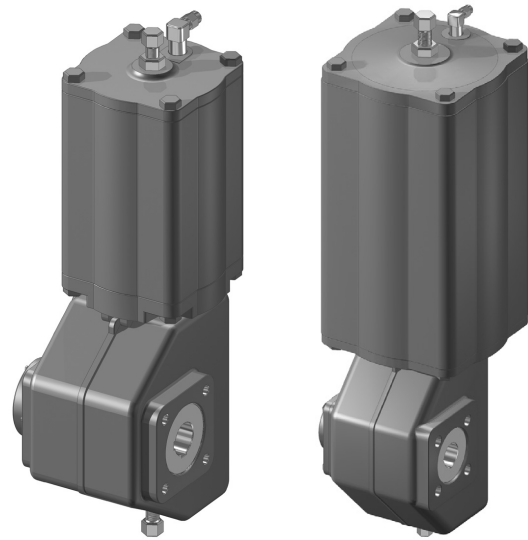

High-and-low temperature construction

The standard unit can be used in temperatures up to 70 °C (158 °F). High temperature construction is available for temperatures up to 120 °C (248 °F). The standard unit can be used down to -20 °C (-4 °F). A low temperature design is available for -40° to +70 °C (-40° to 158 °F), arctic service please refer type coding.

High cycle option

For applications where very fast and high frequency operation is required.

ATEX compatibility

Actuator construction ATEX approved.

Oversized cylinder options

The oversized cylinders (B1C 60, 75, 602, 752) are used whenever the supply pressure is limited, thus the actuators can achieve the required torques with a lower supply pressure level.

Override options

Available override devices include a manual centerpiece handle, a manual handwheel override, and a manual hydraulic override for high torque applications.

Emergency shut-down

Emergency Shut-Down (ESD) valves utilizing B1J actuators are offered to assure operation in the event of a fire or plant malfunction. The ESD device enables valve operational testing without cycling, see bulletin 6B21.

ACTUATOR, SERIES B1C

Lock-out device

Mechanical lock-outs are available to lock the actuator in either the open or closed position, when security considerations are necessary.

Accessories and control devices

A variety of accessories are available including Neles positioners and limit switches, position indicators, solenoid valves, transducers, relays, boosters and volume tanks etc.

The B1C-series actuator is designed for quarter-turn action for control as well as for on-off services. The double-acting cylinder actuator is pneumatically operated. The linkage provides an output characteristic that surpasses the nominal torque at the starting point ($\beta = 0^\circ$).

Applications: E.g. Quarter-turn valves. Compressor anti-surge and recirculate controls. Damper drivers equipped with rack, shaft and lever arm.

Technical data

Actuator type	Cylinder bore mm/inch	Swept volume liters/in ³	Maximum shaft bore mm/inch	Maximum operating pressure bar/psi
B1C6	80/3.15	0.33/20	25/0.98	8.5/120
B1C9	100/3.94	0.60/37	35/1.38	8.5/120
B1C11	125/4.92	1.10/67	40/1.57	8.5/120
B1C13	160/6.30	2.30/140	55/2.17	8.5/120
B1C17	200/7.87	4.30/262	55/2.17	8.5/120
B1C20	200/7.87	5.40/329	70/2.76	10/145
B1C25	250/9.84	10.50/640	95/3.74	10/145
B1C32	315/12.40	21/1280	105/4.13	10/145
B1C40	400/15.75	43/2620	120/4.72	10/145
B1C50	500/19.69	84/5130	135/5.31	10/145
B1C60	600/23.62	121/7380	135/5.31	8.5/120
B1C75	750/29.53	189/11500	135/5.31	5/70
B1C502	500/19.69	195/11900	180/7.09	10/145
B1C602	600/23.62	282/17200	180/7.09	8.5/120
B1C752	750/29.53	441/26900	180/7.09	5/70

EXPLODED VIEWS AND PARTS LISTS ACTUATORS B1C 6

Item	Qty	Description	Materials
1	1	Housing	Aluminum alloy
2	1	Cover	Aluminum alloy
3	1	Lever arm	Ductile iron + nickel
3A	1	Antistatic ring	Brass
4	2	Connection arm	Ductile iron
4A	1	Antistatic ring	Stainless steel
5	1	Bearing unit	Ductile iron+nickel
7	1	Pointer cover	Aluminum alloy
8	1	Cylinder	Aluminum alloy, anodized
9	1	Piston	Aluminum alloy
10	1	Piston rod	Steel, hard chrome plated
16	1	O-ring	Nitrile rubber
17	2	O-ring	Nitrile rubber
18	1	O-ring	Nitrile rubber
19	1	O-ring	Nitrile rubber
20	2	Bearing	Steel+PTFE
21	2	Bearing	Steel+PTFE
22	1	Bearing	PE-HD
23	2	Bearing	PE-HD
24	2	Piston seal	PE-HD
26	1	Stop screw	Stainless steel
27	1	Stop screw	Stainless steel
28	1	Screw	Stainless steel
29	1	Screw	Stainless steel
30	5	Screw	Stainless steel
31	3	Screw	Stainless steel
32	2	Screw	Stainless steel
33	1	Nut	Stainless steel
33A	1	O-ring	Nitrile rubber
34	1	Nut	Stainless steel
36	2	Lock ring	Steel
37	2	Support ring	Steel
39	1	ID plate	Polyester
42	2	Plug	Plastic
44	1	Cylinder end	Aluminum alloy
45	4	Screw	Stainless steel
49	1	Bushing	Steel
58	1	Pressure outlet valve	Epdm rubber
60	1	O-ring	Nitrile rubber
67	1	Screw	Stainless steel

ACTUATORS B1C 9-32

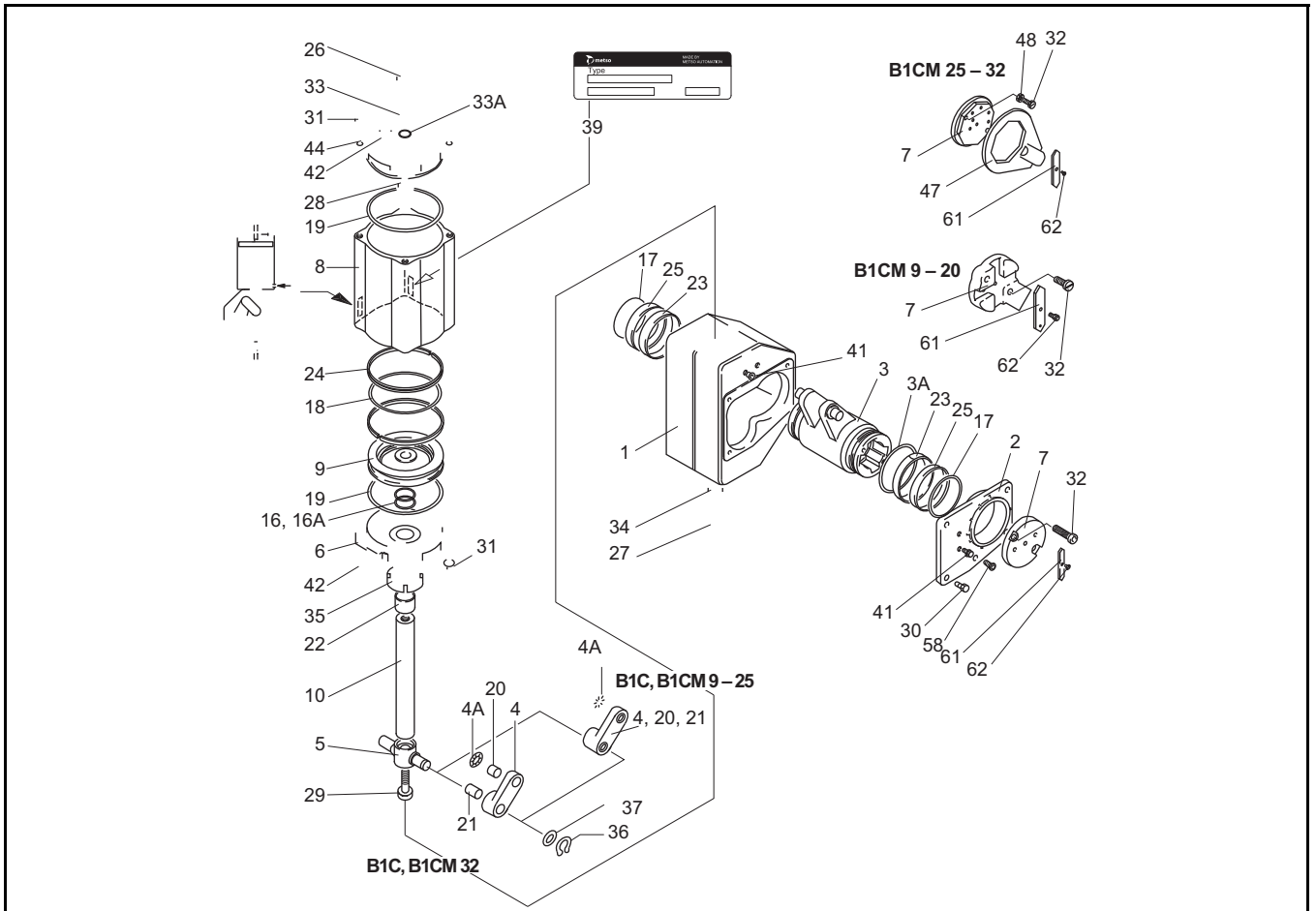

Item	Qty	Description	Materials
1	1	Housing	Cast iron
2	1	Cover	Cast iron
3	1	Lever arm	Ductile iron + nickel
3A	1	Antistatic ring	Brass
4	2	Connection arm	Ductile iron
4A	1	Antistatic ring	Stainless steel
5	1	Bearing unit	Ductile iron + nickel
6	1	Cylinder base	Ductile iron
7	1	Pointer cover	Aluminum alloy
8	1	Cylinder	Aluminum alloy, anodized
9	1	Piston	Cast iron
10	1	Piston rod	Steel, hard chrome plated
16	1	O-ring	Nitrile rubber
16 A	1	O-ring	Nitrile rubber
17	2	O-ring	Nitrile rubber
18	1	O-ring	Nitrile rubber
19	2	O-ring	Nitrile rubber
20	2	Bearing	Steel+PTFE, Bronze+PTFE
21	2	Bearing	Steel+PTFE, Bronze+PTFE
22	1, 2	Bearing	PE-HD
23	2	Bearing	PE-HD
24	2,3	Piston seal	PE-HD
25	2	Bushing	Stainless steel

Item	Qty	Description	Materials
26	1	Stop screw	Stainless steel
27	1	Stop screw	Stainless steel
28	1	Screw	Steel, zincd
29	1	Screw	Steel, zincd
30	4	Screw	Stainless steel
31	8,12	Screw	Stainless steel
32	2	Screw	Stainless steel
33	1	Nut	Stainless steel
34	1	Nut	Stainless steel
35	1	Lock nut	Steel
36	2	Lock ring	Steel
37	2	Support ring	Steel
39	1	ID plate	Polyester
41		Plug	Stainless steel
42		Plug	Plastic
44	1	Cylinder end	Ductile iron
47	1	Torsion arm	Steel
48	2	Washer	Steel
58	1	Pressure outlet valve	EPDM rubber
61	1	Direction arrow	Aluminum alloy
62	1	Screw	Stainless steel

ACTUATORS B1C 40-75

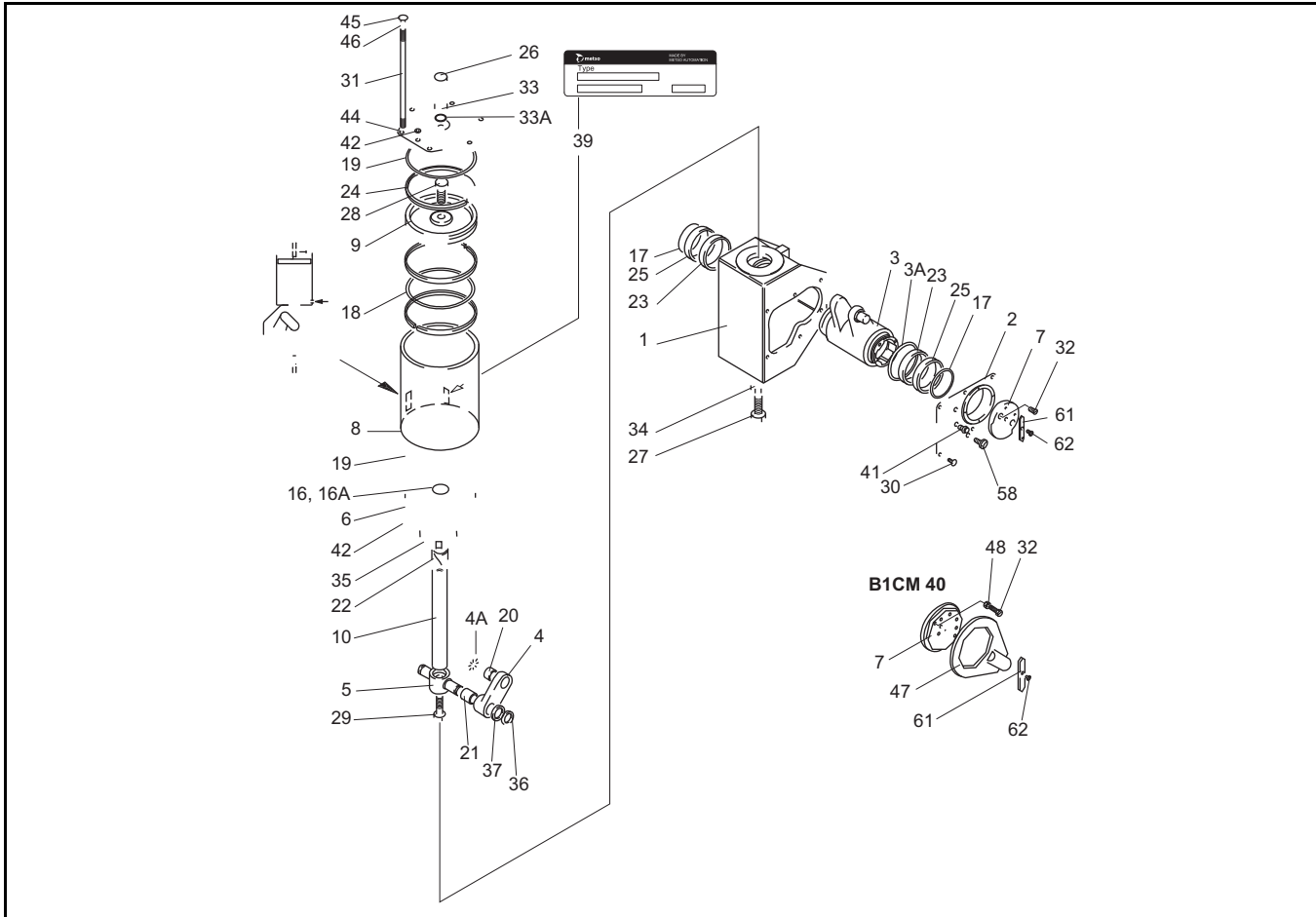

Item	Qty	Description	Materials
1	1	Housing	Steel
2	1	Cover	Steel
3	1	Lever arm	Ductile iron + nickel
3A	1	Antistatic ring	Brass
4	2	Connection arm	Ductile iron
4A	1	Antistatic ring	Stainless steel
5	1	Bearing unit	Ductile iron + nickel
6	1	Cylinder base	Ductile iron
7	1	Pointer cover	Aluminum alloy
8	1	Cylinder	Aluminum alloy, anodized
9	1	Piston	Cast iron
10	1	Piston rod	Steel, hard chrome plated
16	1	O-ring	Nitrile rubber
16A	1	O-ring	Nitrile rubber
17	2	O-ring	Nitrile rubber
18	1	O-ring	Nitrile rubber
19	2	O-ring	Nitrile rubber
20	2	Bearing	Bronze net+PTFE
21	2	Bearing	Bronze net+PTFE
22	2	Bearing	PE-HD
23	2	Bearing	PE-HD
24	3, 4	Piston seal	PE-HD
25	2	Bushing	Stainless steel
26	1	Stop screw	Stainless steel

Item	Qty	Description	Materials
27	1	Stop screw	Stainless steel
28	1	Screw	Steel, zincd
29	1	Screw	Steel, zincd
30	6	Screw	Stainless steel
31	6	Stud	Steel, zincd
32	2	Screw	Stainless steel
33	1	Nut	Stainless steel
33A	1	O-ring	Nitrile rubber
34	1	Nut	Stainless steel
35	1	Lock nut	Steel
36	2	Lock ring	Steel
37	2	Support ring	Steel
39	1	ID plate	Polyester
41		Plug	Stainless steel
42		Plug	Plastic
44	1	Cylinder end	Ductile iron
45	6	Nut	Steel, zincd
46	6	Washer	Steel, zincd
47	1	Torsion arm	Steel
48	2	Washer	Steel
58	1	Pressure outlet valve	EPDM Rubber
61	1	Direction arrow	Aluminum alloy
62	1	Screw	Stainless steel

ACTUATORS B1C 502-752

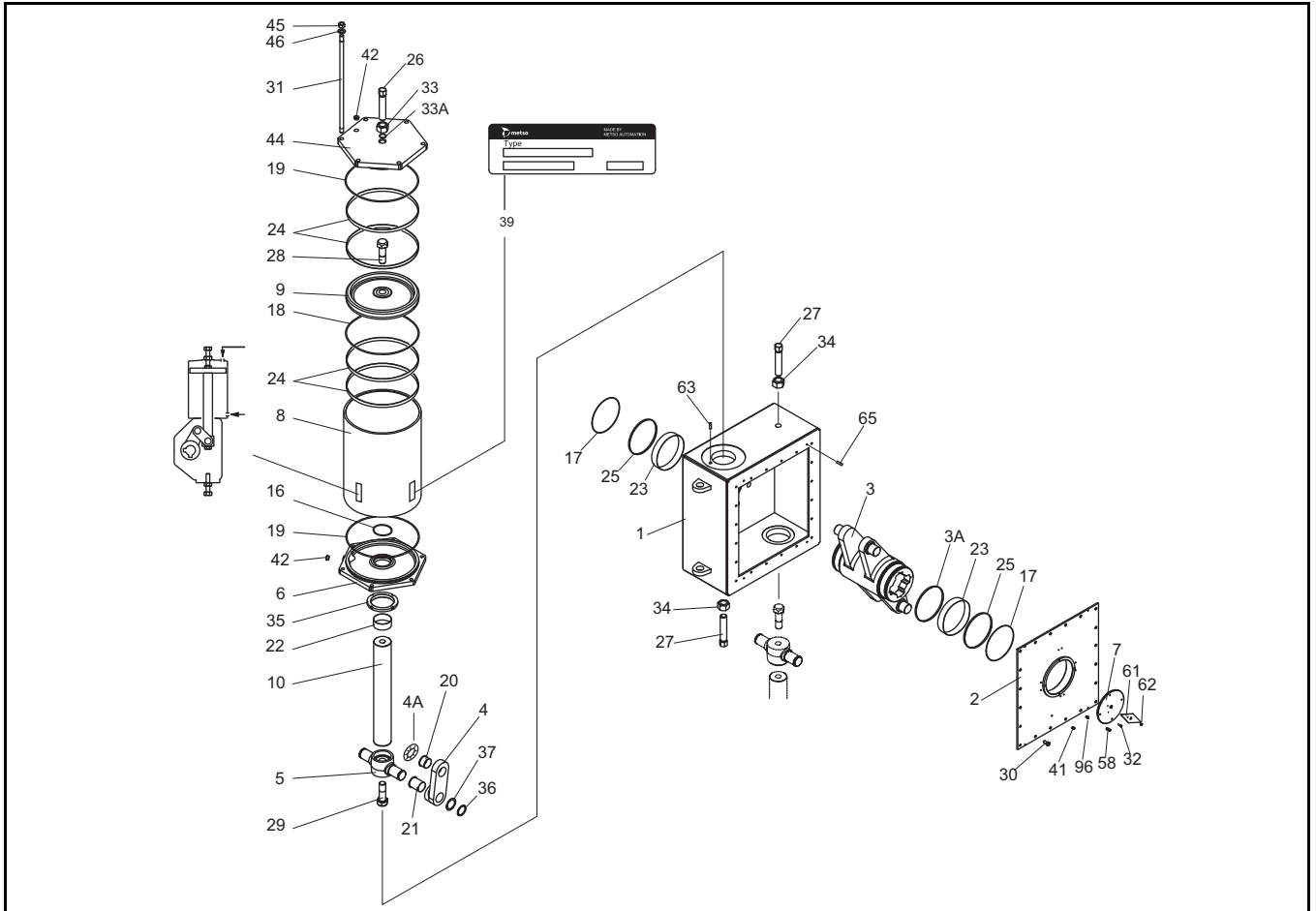

Item	Qty	Description	Materials
1	1	Housing	Steel
2	1	Cover	Steel
3	1	Lever arm	Ductile iron + nickel
3A	1	Antistatic ring	Brass
4	4	Connection arm	Ductile iron
4A	1	Antistatic ring	Stainless steel
5	2	Bearing unit	Ductile iron + nickel
6	2	Cylinder base	Ductile iron
7	1	Pointer cover	Aluminum alloy
8	2	Cylinder	Aluminum alloy, anodized
9	2	Piston	Cast iron
10	2	Piston rod	Steel, hard chrome plated
16	2	O-ring	Nitrile rubber
17	2	O-ring	Nitrile rubber
18	2	O-ring	Nitrile rubber
19	4	O-ring	Nitrile rubber
20	4	Bearing	Bronze net+PTFE
21	4	Bearing	Bronze net+PTFE
22	4	Bearing	PE-HD
23	2	Bearing	PE-HD
24	8	Piston seal	PE-HD
25	2	Bushing	Stainless steel
26	2	Stop screw	Stainless steel

Item	Qty	Description	Materials
27	2	Stop screw	Stainless steel
28	2	Screw	Steel, zincd
29	2	Screw	Steel, zincd
30	20	Screw	Stainless steel
31	12	Stud	Steel, zincd
32	2	Screw	Stainless steel
33	2	Nut	Stainless steel
33A	2	O-ring	Nitrile rubber
34	2	Nut	Stainless steel
35	2	Lock nut	Steel
36	4	Lock ring	Steel
37	4	Support ring	Steel
39	1	ID plate	Polyester
41	4	Plug	Stainless steel
42	4	Plug	Plastic
44	2	Cylinder end	Ductile iron
45	12	Nut	Steel, zincd
46	12	Washer	Steel, zincd
58	1	Pressure outlet valve	EPDM rubber
61	1	Direction arrow	Aluminum alloy
62	2	Screw	Stainless steel
63	2	Pin	Steel
65	4	Pin	Steel

DOUBLE ACTING ACTUATOR, SERIES B1C

OPERATION

The linkage mechanism within the B-series actuator converts linear motion of the piston into a 90° (max. 98°) rotation of the actuator shaft. The line in the figure on the right shows torque characteristics vs. actuator shaft angle.

Max. torque is achieved at $\beta = 0^\circ$ which usually corresponds to the closed position of ball and butterfly valves and where max. seat torque normally appears.

Another peak is achieved at 60-80° which corresponds to the dynamic torque peak of butterfly valves. The torques in the table below show the minimum torque M_n at different supply pressures.

SELECTION

To select the proper actuator for a particular valve and service, first determine the maximum operating torque that will be required for the valve from the applicable valve torque table, then refer to the appropriate mode of operation of the actuator in the torque output tables below and select the actuator that will, at the available air supply pressure, provide a torque output no less than the required operating torque for the valve. If in doubt, select the next larger actuator.

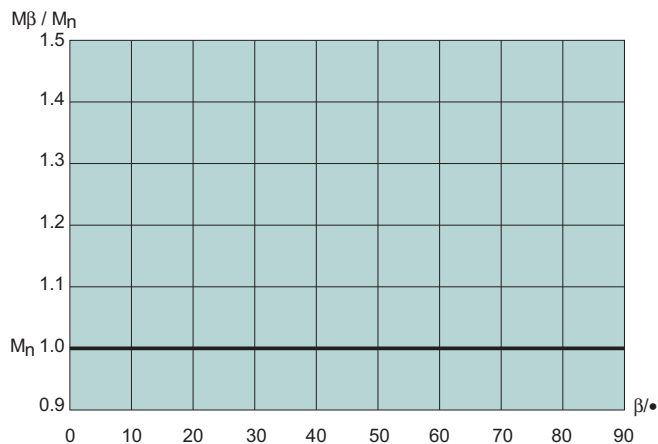

Output torque as a function of turning angle.

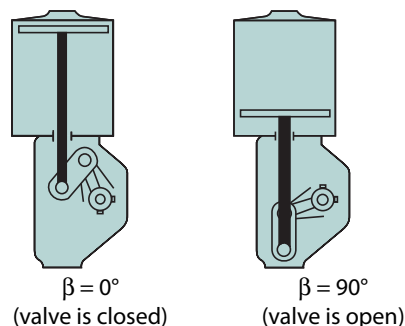

ACTUATOR TORQUE M_n

Actuator type	Torque Output M_n Nm - ft-lbs at Specific Supply Pressure bar - psi													
	3.0 bar 43 psi		3.5 bar 50 psi		4 bar 58 psi		5 bar 72 psi		5.5 bar 80 psi		6 bar 87 psi		7 bar 102 psi	
	Nm	lbf ft	Nm	lbf ft	Nm	lbf ft	Nm	lbf ft	Nm	lbf ft	Nm	lbf ft	Nm	lbf ft
B1C 6	45	30	51	38	60	45	75	55	82	60	90	65	100	75
B1C 9	85	60	100	75	115	90	145	110	160	120	175	130	205	150
B1C11	160	120	185	137	220	160	270	200	300	220	330	240	375	280
B1C13	330	245	390	290	460	335	565	415	620	460	675	505	790	585
B1C17	620	460	720	530	850	625	1040	780	1160	850	1260	930	1570	1085
B1C20	750	560	880	650	1030	760	1290	940	1400	1040	1550	1140	1780	1320
B1C25	1450	1070	1700	1250	2010	1460	2500	1830	2700	2000	3000	2230	3450	2540
B1C32	2890	2140	3400	2500	4000	2930	5000	3650	5500	4100	6000	4450	7000	5170
B1C40	6100	4490	7100	5200	8290	6150	10310	7600	11300	8400	12290	9100	14300	10550
B1C50	11770	8770	13900	10200	16290	12000	20210	14900	22000	16300	24190	17810	28100	20700
B1C60	17330	11980	20300	15000	23710	17460	29580	21770	32400	23900	35320	26030	41190	30440
B1C75	27180	20010	31700	23400	37170	27420	46250	34060						
B1C502	26540	19580	31000	22900	36290	26830	44790	33330	49600	36600	54500	39870	63000	46460
B1C602	38200	28140	44600	32900	52200	38540	65110	48020	71400	52700	77710	57290	90490	66750
B1C752	60240	44410	70300	51900	82340	60680	102710	75630						

Note: The actuator can be used at higher supply pressures than shown in the table. Maximum supply pressures are listed in the table on page 2.

Example 1.

Required torque: 130 Nm / 98 lbf ft.

Air supply pressure ps = 4.8 bar / 70 psi.

On-off service.

B1C9 output torque is 140 Nm / 104 lbf ft.

Select B1C9

B1C attachment according to the ISO 5211.

ACTUATOR, SERIES B1J

The B1J-series actuator is designed for quarter turn action for control as well as for on-off services. The spring-return cylinder actuator is pneumatically operated. The linkage provides an output characteristic that surpasses the nominal torque at the starting point ($\beta = 0^\circ$).

Applications: E.g. quarter-turn valves.
 Damper drivers equipped with rack, shaft and lever arm.

Actuator type	Cylinder bore mm/inch	Swept volume liters/in ³	Maximum shaft bore mm/inch	Maximum operating pressure bar/psi
B1J6	100/3.94	0.47/28.7	25/0.98	8.5/120
B1J8	125/4.92	0.9/55	35/1.38	8.5/120
B1J10	160/6.30	1.80/111	40/1.57	8.5/120
B1J12	200/7.87	3.60/225	55/2.17	8.5/120
B1J16	250/9.84	6.70/415	55/2.17	8.5/120
B1J20	315/12.40	13/795	70/2.76	8.5/120
B1J25	400/15.75	27/1642	95/3.74	8.5/120
B1J32	500/19.69	53/3231	105/4.13	8.5/120
B1J40	600/23.62	96.7/5901	120/4.72	8.5/120
B1J322	500/19.69	106/6480	120/4.72	8.5/120

EXPLODED VIEWS AND PARTS LISTS ACTUATORS B1J 6-20

Item	Qty	Description	Materials
1	1	Housing	Cast iron
2	1	Cover	Cast iron
3	1	Lever arm	Ductile iron + nickel
3A	1	Antistatic ring	Brass
4	2	Connection arm	Ductile iron
4A	1	Antistatic ring	Stainless steel
5	1	Bearing unit	Ductile iron + nickel
6	1	Cylinder base	Ductile iron
7	1	Pointer cover	Aluminum alloy
8	1	Cylinder	Aluminum alloy, anodized
9	1	Piston	Cast iron
10	1	Piston rod	Steel, hard chrome plated
11	1	Spring	Steel
12	1	Spring plate	Steel, zincd
13	1	Clamping tube	Steel
14	2	Lock ring	Steel
15	1	Hexagon nut	Steel
16	1	O-ring	Nitrile rubber
16A	1	O-ring	Nitrile rubber
17	2	O-ring	Nitrile rubber
18	1	O-ring	Nitrile rubber
19	2	O-ring	Nitrile rubber
20	2	Bearing	DU-type, steel+PTFE
21	2	Bearing	DU-type, steel+PTFE
22	1	Bearing	PE-HD
23	2	Bearing	PE-HD
24	3	Piston seal	PE-HD
25	2	Bushing	Stainless steel
26	1	Stop screw	Stainless steel
27	1	Stop screw	Stainless steel
29	1	Screw	Steel, zincd
30	4	Screw	Stainless steel
31	8, 12	Screw	Stainless steel
32	2	Screw	Stainless steel
33	1	Nut	Stainless steel
33A	1	O-ring	Nitrile rubber
34	1	Nut	Stainless steel
35	1	Lock nut	Steel
36	2	Lock ring	Steel
37	2	Support ring	Steel
39	1	ID plate	Polyester
40	1	Filter	Stainless steel
41	4	Plug	Stainless steel
42	1	Plug	Plastic
43	1	Warning plate	Plastic
44	1	Cylinder end	Ductile iron
58	1	Pressure outlet valve	EPDM Rubber
61	1	Direction arrow	Aluminum alloy
62	1	Screw	Stainless steel

ACTUATORS B1J 25-40

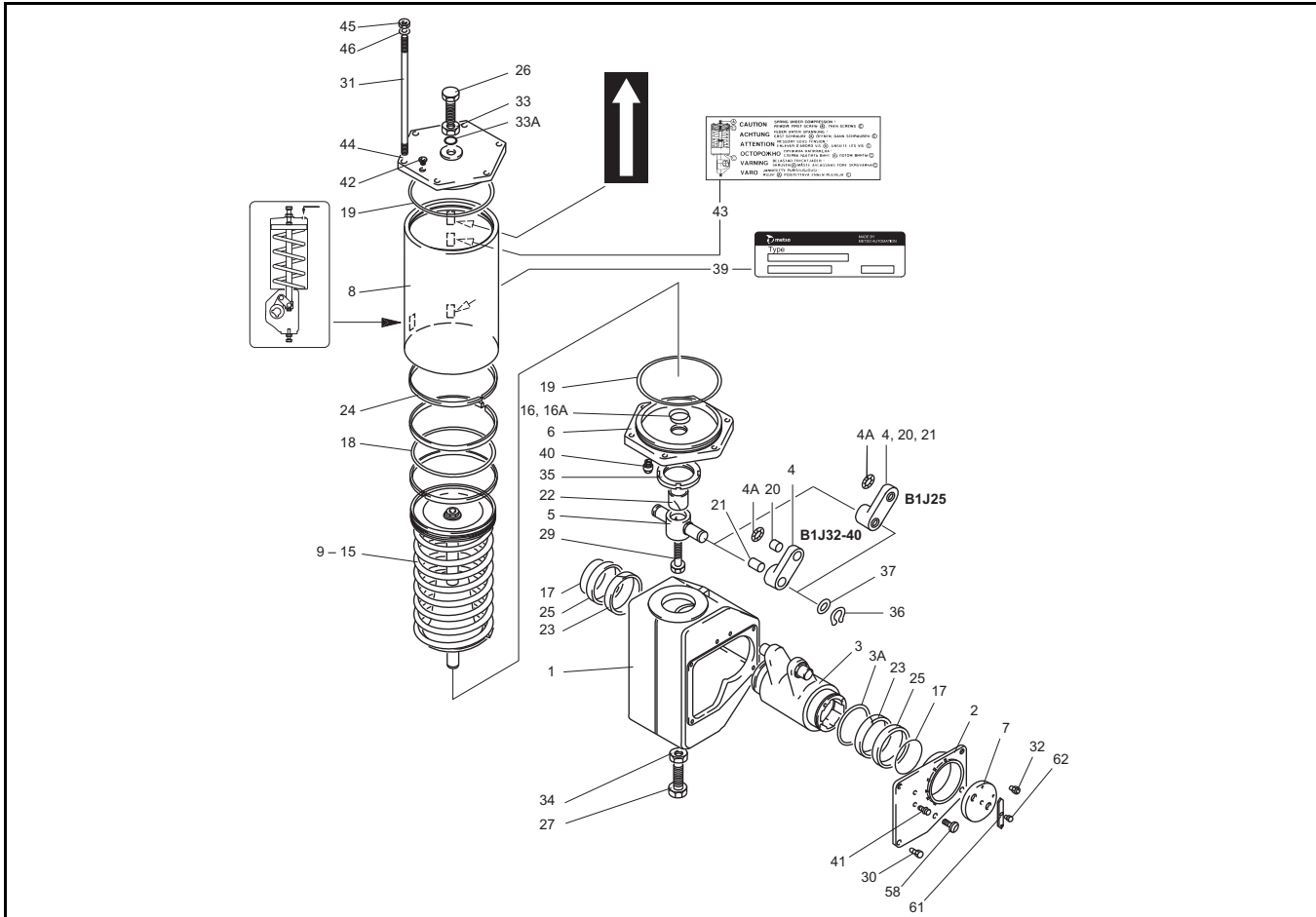

Item	Qty	Description	Materials
1	1	Housing	Cast iron/Steel (BJ40)
2	1	Cover	Cast iron
3	1	Lever arm	Ductile iron + nickel
3A	1	Antistatic ring	Brass
4	2	Connection arm	Ductile iron
4A	1	Antistatic ring	Stainless steel
5	1	Bearing unit	Ductile iron + nickel
6	1	Cylinder base	Ductile iron
7	1	Pointer cover	Aluminum alloy
8	1	Cylinder	Aluminum alloy, anodized
9	1	Piston	Cast iron
10	1	Piston rod	Steel, hard chrome plated
11	1	Spring	Steel
12	1	Spring plate	Steel, zincd
13	1	Clamping tube	Steel
14	2	Lock ring	Steel
15	1	Hexagon nut	Steel
16	1	O-ring	Nitrile rubber
16A	1	O-ring	Nitrile rubber
17	2	O-ring	Nitrile rubber
18	1	O-ring	Nitrile rubber
19	1	O-ring	Nitrile rubber
20	2	Bearing	Steel+PTFE, Bronze+PTFE
21	2	Bearing	Steel+PTFE, Bronze+PTFE
22	1, 2	Bearing	PE-HD
23	2	Bearing	PE-HD

Item	Qty	Description	Materials
24	3, 4	Piston seal	PE-HD
25	2	Bushing	Stainless steel
26	1	Stop screw	Stainless steel
27	1	Stop screw	Stainless steel
29	1	Screw	Steel, zincd
30	4	Screw	Stainless steel
31	6	Stud	Steel, zincd
32	2	Screw	Stainless steel
33	1	Nut	Stainless steel
33A	1	O-ring	Nitrile rubber
34	1	Nut	Stainless steel
35	1	Lock nut	Steel
36	2	Lock ring	Steel
37	2	Support ring	Steel
39	1	ID plate	Polyester
40	1	Filter	Stainless steel
41	4	Plug	Stainless steel
42	1	Plug	Plastic
43	1	Warning plate	Aluminum sticker
44	2	Cylinder end	Ductile iron
45	6	Nut	Steel, zincd
46	6	Washer	Steel, zincd
58	1	Pressure outlet valve	EPDM rubber
61	1	Direction arrow	Aluminum plate
62	1	Screw	Stainless steel

ACTUATORS B1JA 6-20

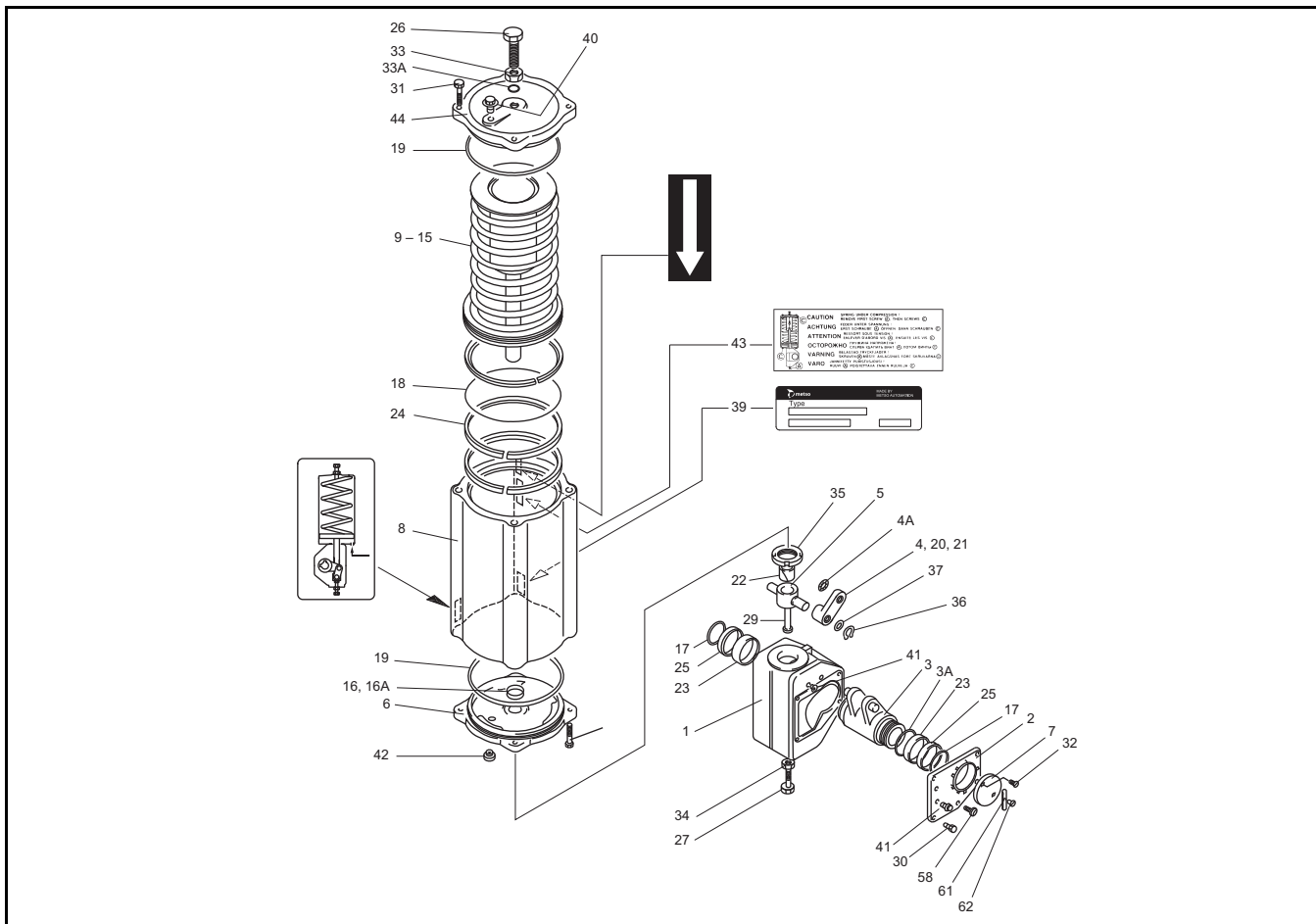

Item	Qty	Description	Materials
1	1	Housing	Cast iron
2	1	Cover	Cast iron
3	1	Lever arm	Ductile iron + nickel
3A	1	Antistatic ring	Brass
4	2	Connection arm	Ductile iron
4A	1	Antistatic ring	Stainless steel
5	1	Bearing unit	Ductile iron + nickel
6	1	Cylinder base	Ductile iron
7	1	Pointer cover	Aluminum alloy
8	1	Cylinder	Aluminum alloy, anodized
9	1	Piston	Cast iron
10	1	Piston rod	Steel, hard chrome plated
11	1	Spring	Steel
12	1	Spring plate	Steel, zincd
13	1	Clamping tube	Steel
14	2	Lock ring	Steel
15	1	Hexagon nut	Steel
16	1	O-ring	Nitrile rubber
16A	1	O-ring	Nitrile rubber
17	2	O-ring	Nitrile rubber
18	1	O-ring	Nitrile rubber
19	1	O-ring	Nitrile rubber
20	2	Bearing	DU-type, steel+PTFE
21	2	Bearing	DU-type, steel+PTFE

Item	Qty	Description	Materials
22	1	Bearing	PE-HD
23	2	Bearing	PE-HD
24	3	Piston seal	PE-HD
25	2	Bushing	Stainless steel
29	1	Screw	Steel, zincd
30	4	Screw	Stainless steel
31	8, 12	Screw	Stainless steel
32	2	Screw	Stainless steel
33	1	Nut	Stainless steel
33A	1	O-ring	Nitrile rubber
34	1	Nut	Stainless steel
35	1	Lock nut	Steel
36	2	Lock ring	Steel
37	2	Support ring	Steel
39	1	ID plate	Polyester
41	4	Plug	Stainless steel
42	1	Plug	Plastic
43	1	Warning plate	Plastic
44	1	Cylinder end	Ductile iron
58	1	Pressure outlet valve	EPDM rubber
61	1	Direction arrow	Aluminum alloy
62	1	Screw	Stainless steel

ACTUATOR B1JA 25-40

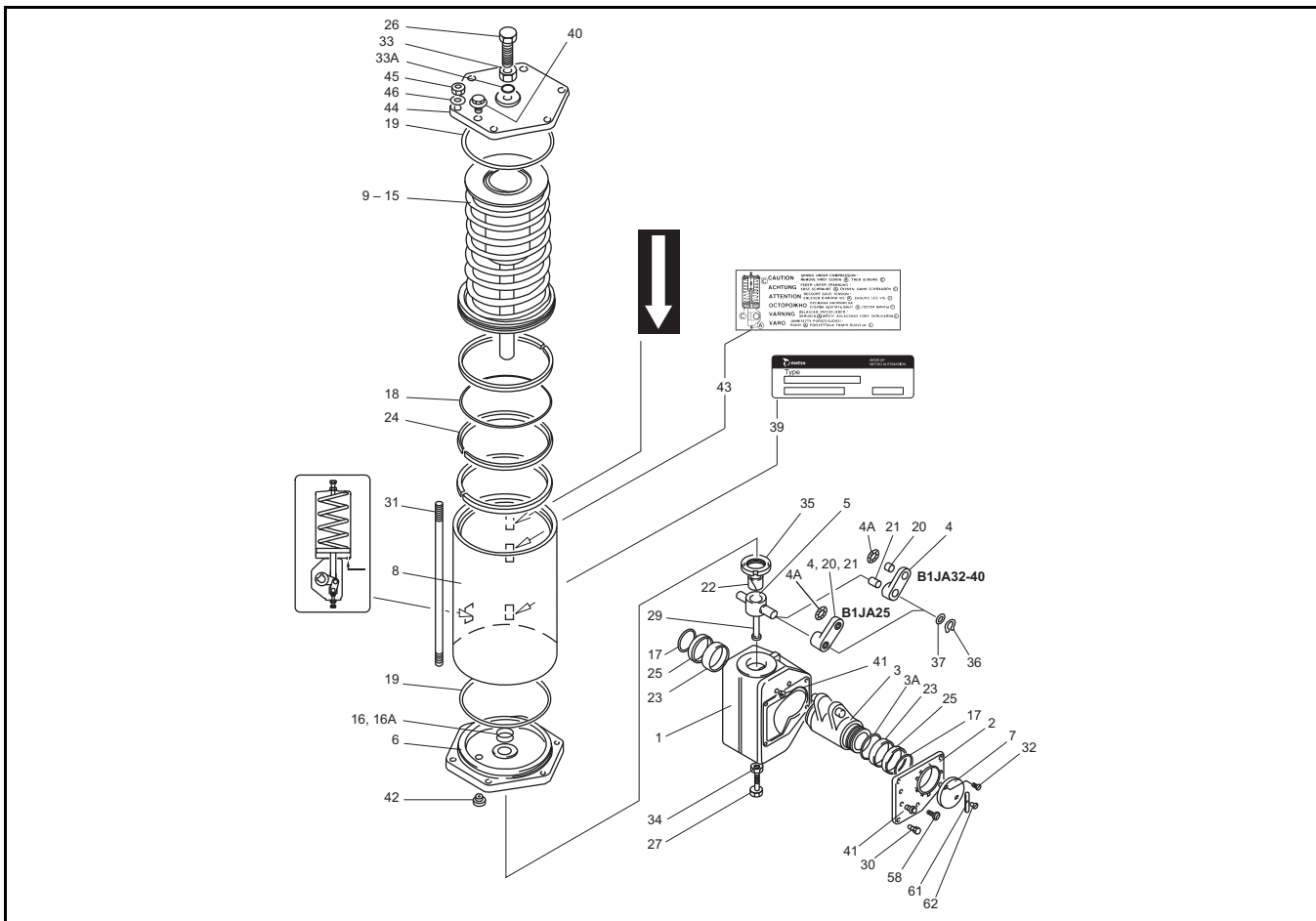

Item	Qty	Description	Materials
1	1	Housing	Cast iron
2	1	Cover	Cast iron
3	1	Lever arm	Ductile iron + nickel
3A	1	Antistatic ring	Brass
4	2	Connection arm	Ductile iron
4A	1	Antistatic ring	Stainless steel
5	1	Bearing unit	Ductile iron + nickel
6	1	Cylinder base	Ductile iron
7	1	Pointer cover	Aluminum alloy
8	1	Cylinder	Aluminum alloy, anodized
9	1	Piston	Cast iron
10	1	Piston rod	Steel, hard chrome plated
11	1	Spring	Steel
12	1	Spring plate	Steel
13	1	Clamping tube	Steel
14	2	Lock ring	Steel
15	1	Hexagon nut	Steel
16	1	O-ring	Nitrile rubber
16A	1	O-ring	Nitrile rubber
17	2	O-ring	Nitrile rubber
18	1	O-ring	Nitrile rubber
19	1	O-ring	Nitrile rubber
20	2	Bearing	Steel+PTFE, Bronze net+PTFE
21	2	Bearing	Steel+PTFE, Bronze net+PTFE
22	1, 2	Bearing	PE-HD
23	2	Bearing	PE-HD

Item	Qty	Description	Materials
24	3, 4	Piston seal	PE-HD
25	2	Bushing	Stainless steel
26	1	Stop screw	Stainless steel
27	1	Stop screw	Stainless steel
29	1	Screw	Steel, zincd
30	4	Screw	Stainless steel
31	6	Stud	Steel, zincd
32	2	Screw	Stainless steel
33	1	Nut	Stainless steel
33A	1	O-ring	Nitrile rubber
34	1	Nut	Stainless steel
35	1	Lock nut	Steel
36	2	Lock ring	Steel
37	2	Support ring	Steel
39	1	ID plate	Polyester
40	1	Filter	Stainless steel
41	4	Plug	Stainless steel
42	1	Plug	Plastic
43	1	Warning plate	Plastic
44	1	Cylinder end	Ductile iron
45	6	Nut	Steel, zincd
46	6	Washer	Steel, zincd
58	1	Pressure outlet valve	EPDM rubber
61	1	Direction arrow	Aluminum plate
62	1	Screw	Stainless steel

ACTUATOR B1JA 322

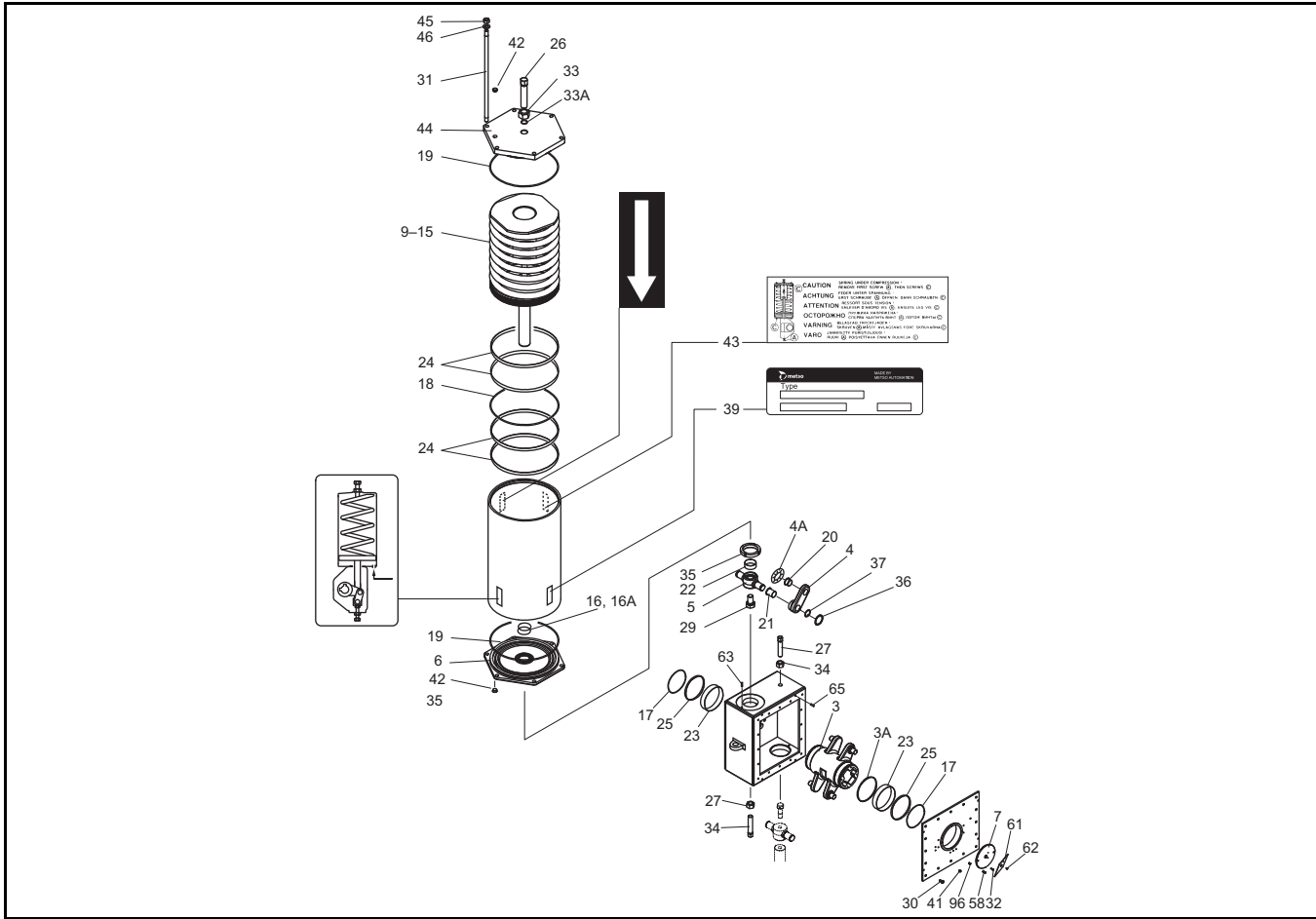

Item	Qty	Description	Materials
1	1	Housing	Steel
2	1	Cover	Steel
3	1	Lever arm	Ductile iron+nickel
3A	1	Antistatic ring	Brass
4	4	Connection arm	Ductile iron
4A	1	Antistatic ring	Stainless steel
5	2	Bearing unit	Ductile iron+nickel
6	2	Cylinder base	Ductile iron
7	1	Pointer cover	Aluminum alloy
8	1	Cylinder	Aluminum alloy, anodized
9	2	Piston	Cast iron
10	2	Piston rod	Steel, hard chrome plated
11	2	Spring	Steel
12	2	Spring plate	Steel
13	2	Clamping tube	Steel
14	4	Lock ring	Steel
15	2	Hexagon nut	Steel
16	2	O-ring	Nitrile rubber
16A	2	O-ring	Nitrile rubber
17	2	O-ring	Nitrile rubber
18	2	O-ring	Nitrile rubber
19	4	O-ring	Nitrile rubber
20	4	Bearing	Bronze net+PTFE
21	4	Bearing	Bronze net+PTFE
22	2	Bearing	PE-HD
23	2	Bearing	PE-HD
24	8	Piston seal	PE-HD

Item	Qty	Description	Materials
25	2	Bushing	Stainless steel
26	2	Stop screw	Stainless steel
27	2	Stop screw	Stainless steel
29	2	Screw	Steel, zincd
30	16	Screw	Stainless steel
31	12	Stud	Steel, zincd
32	2	Screw	Stainless steel
33	2	Nut	Stainless steel
33A	2	O-ring	Nitrile rubber
34	2	Nut	Stainless steel
35	2	Lock nut	Steel
36	4	Lock ring	Steel
37	4	Support ring	Steel
39	1	ID plate	Polyester
40	2	Filter	Stainless steel
41	4	Plug	Stainless steel
42	2	Plug	Plastic
43	2	Warning plate	Aluminum sticker
44	2	Cylinder end	Ductile iron
45	2	Hexagon nut	Steel, zincd
46	2	Washer	Steel, zincd
58	1	Pressure outlet valve	EPDM rubber
61	1	Direction arrow	Aluminum plate
62	2	Screw	Stainless steel
63	2	Pin	Steel
65	4	Pin	Steel

SINGLE ACTING ACTUATOR SERIES B1J

OPERATION

The linkage converts linear motion of the piston into a 90° (max. 98°) rotation of the actuator shaft. As a result of the linkage design, the relationship between output torque and piston force depends on the angle of the actuator shaft. The torque output values in the table below show the minimum spring torque (Ms) and the minimum torque (Mp) produced as a result of a specific supply pressure and spring.

ACTUATOR SELECTION

To select the proper actuator for a particular valve and service, first determine the maximum operating torque that will be required for the valve from the applicable valve torque table, then refer to the appropriate mode of operation of the actuator in the torque output tables below and select the actuator that will, at the available air supply pressure, provide a torque output no less than the required operating torque for the valve. If in doubt, select the next larger actuator.

Actuator type	Spring min torque Mn	
	Nm	lbf ft
B1JK6 B1JKA6	28	21
B1J6 B1JA6	36	26
B1JV6 B1JVA6	48	35
B1JK8, B1JKA8	50	37
B1J8, B1JA8	70	50
B1JV8, B1JVA8	90	66
B1JK10, B1JKA10	105	77
B1J10, B1JA10	150	110
B1JV10, B1JVA10	200	150
B1JK12, B1JKA12	210	155
B1J12, B1JA12	300	220
B1JV12, B1JVA12	390	290
B1JK16, B1JKA16	420	310
B1J16, B1JA16	600	440
B1JV16, B1JVA16	780	575
B1JK20, B1JKA20	850	630
B1J20, B1JA20	1200	880
B1JV20, B1JVA20	1500	1100
B1JK25, B1JKA25	1700	1250
B1J25, B1JA25	2400	1760
B1JV25, B1JVA25	3000	2200
B1JK32, B1JKA32	3400	2500
B1J32, B1JA32	4800	3500
B1JV32, B1JVA32	6100	4500
B1JK40 B1JKA40	5700	4207
B1J40, B1JA40	8400	6199
B1JV40, B1JVA40	10900	8044
B1JK322, B1JKA322	6800	5000
B1J322, B1JA322	9600	7000
B1JV322, B1JVA322	12200	9000

ACTUATOR TORQUE, Mn

B1J attachment according to the ISO 5211.
 Note: Maximum allowed supply pressure is 120 psi (8.5 bar).
 B1JK_ has a lighter spring for lower supply pressures.
 B1J_ for medium supply pressures
 B1JV_ has a stronger spring for higher supply pressures.
 Torque outputs for B1J are identical to those shown for BJ.

GENERAL SELECTION PRINCIPLES

The first selection principle for actuator sizing must always be the torque given by the spring.
 Secondly, it must be checked that the available pressure is sufficient to give at least the same torque as the spring, but in the opposite direction.

Spring to close, type B1J

Spring to open, type B1JA

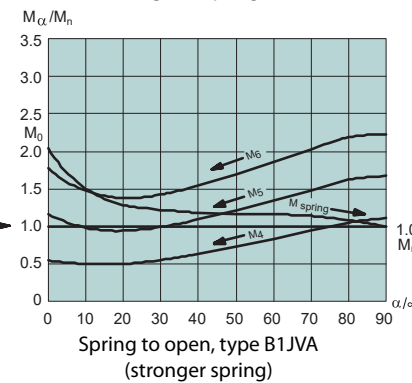
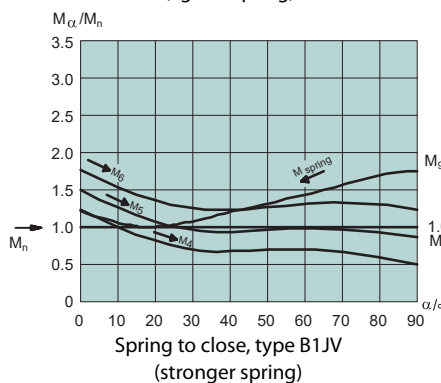
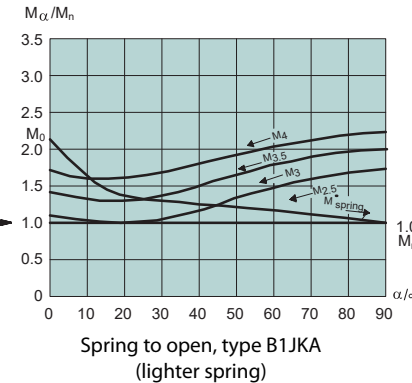
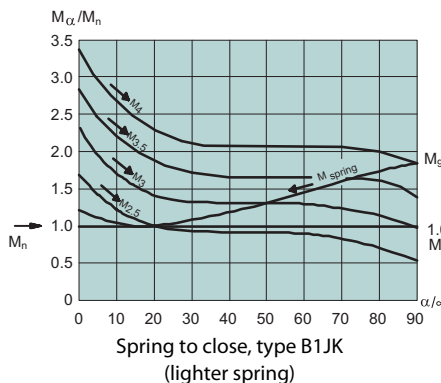
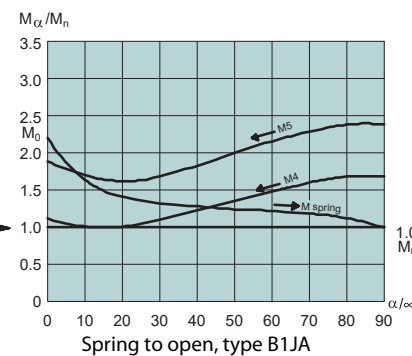
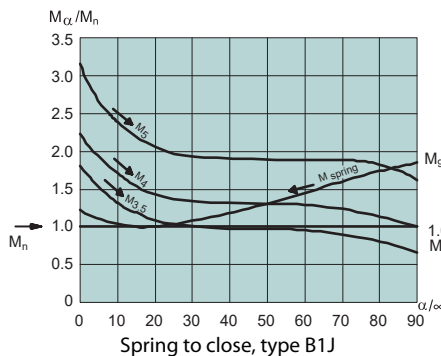
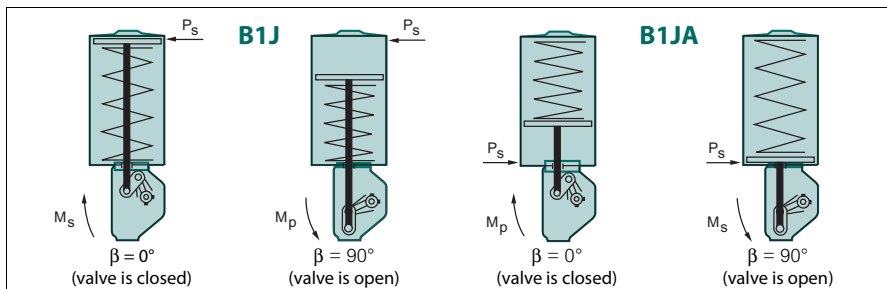

Note: Max. supply pressure 8.5 bar / 120 psi.
 Mn = Nominal running torque
 Mspring = Torque developed by the spring force.
 Mp = Torque developed by the difference of pressure force and spring force (eg. Ms = torque developed with 5 bar). When alpha = 0° the valve is closed.

Example 1.
 Required torque: 130 Nm / 98 lbf ft.
 Required action: Spring-to-close.
 Nominal spring torque, Ms B1J10 = 150 Nm / 110 lbf ft.
 Select B1J10.
 Note: Min. air supply pressure ps = 4.1 bar / 60 psi.

Example 2.
 Required torque: 500 Nm / 370 lbf ft.
 Required action: Spring-to-open.
 Step 1. At the turning angle beta = 90° (valve is fully open), the nominal spring torque B1JA16 is 600 Nm / 440 lbf ft.
 Step 2. When air closes the valve (beta = 0°) the actuator torque (B1JA16) is 650 Nm / 480 lbf ft at 4.1 bar / 60 psi supply pressure.
 Select B1JA16.
 Note: At air supply pressures ps < 4.1 bar / 60 psi, contact factory.

SPECIAL CONSTRUCTIONS

LOCKING DEVICE
On housing end

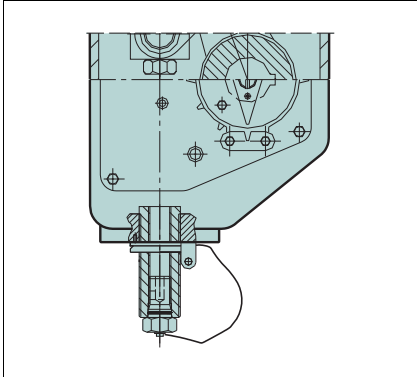

Type code: B1_Q

On cylinder end

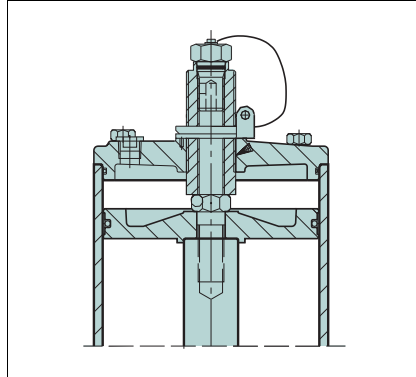

Type code: B1_W

SHOCK ABSORBER ON HOUSING END

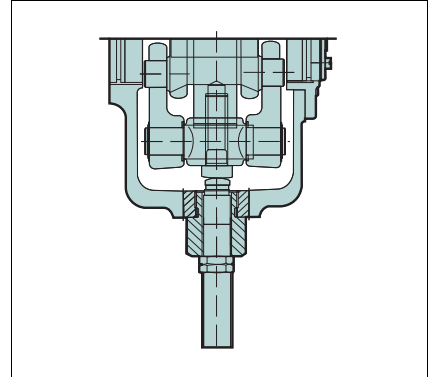

Type code: B1C_N

AUTOMATIC LATCHING DEVICE FOR CLOSED POSITION

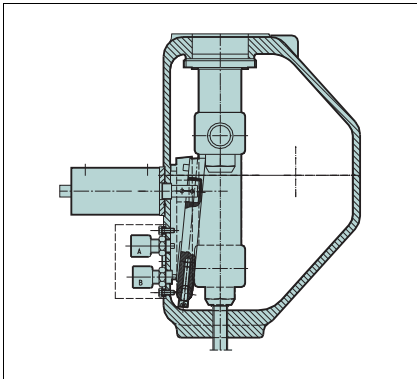

Type code: B1C_P

MANUAL LATCHING DEVICE

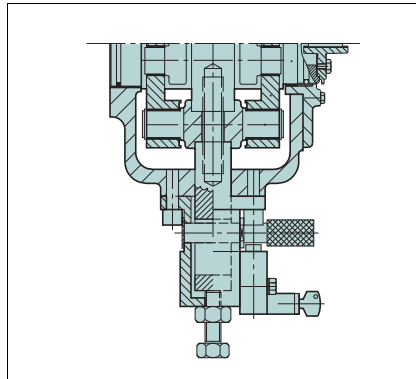

Type code: B1_T

HANDWHEEL
On cylinder end

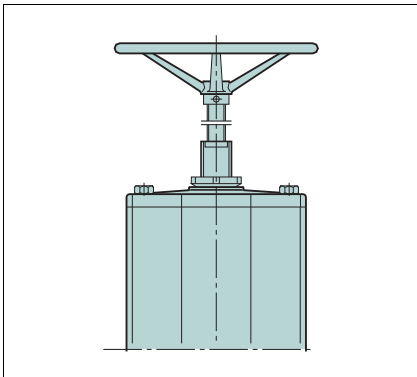

Type code: B1C_K

On housing end

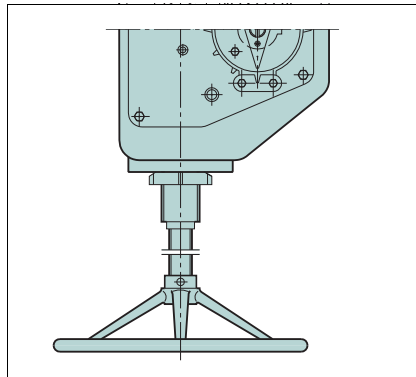

Type code: B1C_L

HYDRAULIC MANUAL OVERRIDE

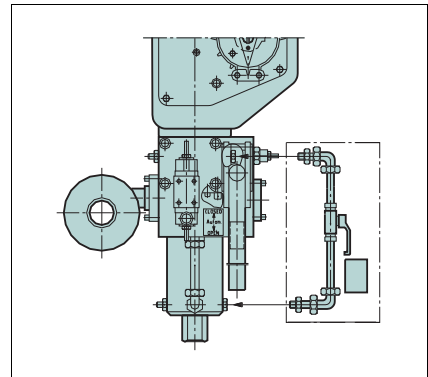

Type code: B1CH

DIMENSIONAL DRAWINGS

ACTUATORS B1C

B1C

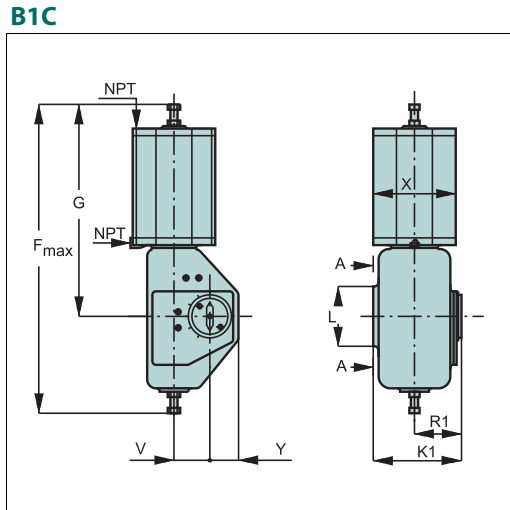

Type	Dimensions, mm								NPT	kg
	X	G	F	V	Y	L	K1	R1		
B1C6	90	270	395	36	46	80	138	80	1/4	4,2
B1C9	110	315	450	43	50	80	140	81	1/4	9,6
B1C11	135	375	535	51	50	95	154	89	3/8	16
B1C13	175	445	640	65	65	120	190	109	3/8	31
B1C17	215	555	785	78	70	137	222	126	1/2	54
B1C20	215	590	880	97	80	145	262	147	1/2	73
B1C25	265	725	1075	121	110	180	304	166	1/2	131
B1C32	395	920	1370	153	146	280	379	204	3/4	256
B1C40	505	1150	1670	194	185	320	449	224	3/4	446
B1C50	610	1390	2060	242	195	350	543	268	1	830
B1C60	725	1390	2060	242	195	350	543	268	1	1080
B1C75	875	1390	2060	242	195	350	543	268	1	1190

Type	Dimensions, inch								NPT	lbs
	X	G	F	V	Y	L	K1	R1		
B1C6	3.54	10.60	15.60	1.42	1.81	3.15	5.43	3.15	1/4	9
B1C9	4.33	12.40	17.70	1.69	1.97	3.15	5.51	3.19	1/4	21
B1C11	5.31	14.80	21.10	2.01	1.97	3.74	6.06	3.50	3/8	35
B1C13	6.89	17.50	25.20	2.56	2.56	4.72	7.48	4.29	3/8	68
B1C17	8.46	21.90	30.90	3.07	2.76	5.39	8.74	4.96	1/2	119
B1C20	8.46	23.20	34.70	3.82	3.15	5.71	10.31	5.79	1/2	161
B1C25	10.43	28.50	42.30	4.76	4.33	7.09	11.97	6.54	1/2	289
B1C32	15.55	36.20	53.90	6.02	5.75	11.0	14.92	8.03	3/4	564
B1C40	19.88	45.30	65.70	7.64	7.28	12.60	17.68	8.82	3/4	983
B1C50	24.02	54.70	81.10	9.53	7.68	13.78	21.38	10.55	1	1829
B1C60	28.54	54.70	81.10	9.53	7.68	13.78	21.38	10.55	1	2380
B1C75	34.45	54.70	81.10	9.53	7.68	13.78	21.38	10.55	1	2620

SPRING RETURN ACTUATORS B1J, B1JA

B1J, B1JA

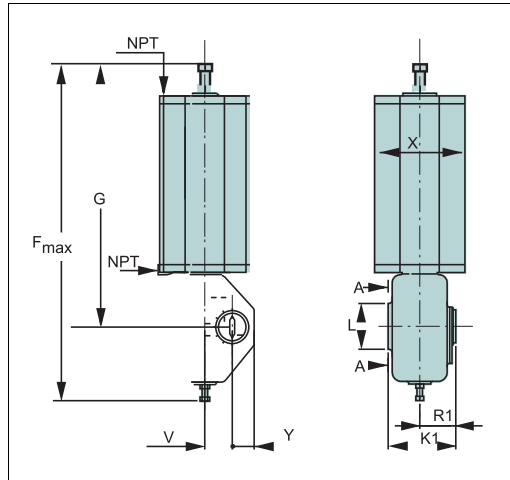

B1J, B1JA

Type	Dimensions, mm								NPT	kg
	X	G	F	V	Y	L	K1	R1		
B1J, B1JA6	110	368	485	36	47	70	138	80	3/8	13
B1J, B1JA8	135	420	555	43	50	80	140	81	3/8	17
B1J, B1JA10	175	480	640	51	50	95	154	89	3/8	30
B1J, B1JA12	215	620	815	65	65	120	190	109	1/2	57
B1J, B1JA16	265	760	990	78	70	137	222	126	1/2	100
B1J, B1JA20	395	940	1230	97	80	145	262	147	3/4	175
B1J, B1JA25	505	1140	1490	121	110	180	304	166	3/4	350
B1J, B1JA32	540	1435	1885	153	146	280	379	204	1	671
B1J, B1JA40	724	1578	2095	194	185	335	445	220	1	1100

Type	Dimensions, inch								NPT	lbs
	X	G	F	V	Y	L	K1	R1		
B1J, B1JA6	4.33	14.49	19.09	1.42	1.85	2.76	5.43	3.15	3/8	28.5
B1J, B1JA8	5.31	16.50	21.90	1.69	1.97	3.15	5.51	3.19	3/8	37
B1J, B1JA10	6.89	18.90	25.20	2.01	1.97	3.74	6.06	3.50	3/8	66
B1J, B1JA12	8.46	24.40	32.10	2.56	2.56	4.72	7.48	4.29	1/2	126
B1J, B1JA16	10.43	29.90	38.00	3.07	2.76	5.39	8.74	4.96	1/2	220
B1J, B1JA20	15.55	37.00	48.40	3.82	3.15	5.71	10.31	5.79	3/4	386
B1J, B1JA25	19.88	44.90	58.70	4.76	4.33	7.09	11.97	6.54	3/4	771
B1J, B1JA32	21.26	56.50	74.20	6.02	5.75	11.0	14.92	8.03	1	1479
B1J, B1JA40	28.5	62.13	82.48	7.64	7.28	13.19	17.52	8.66	1	2424

B1CH

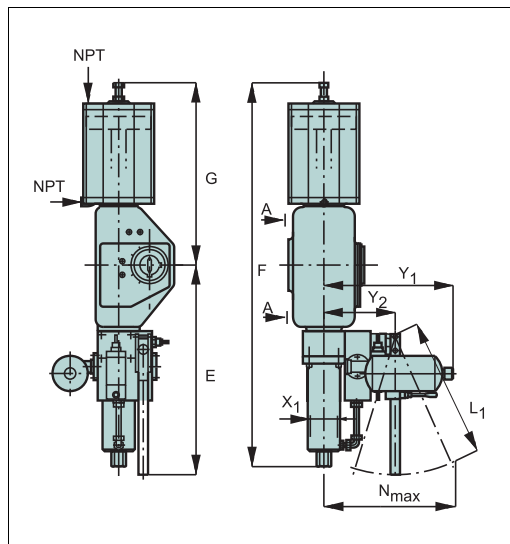

B1CH

Type	Dimensions, mm								NPT	kg
	E	F	G	L1	Nmax	Y1	Y2	X1		
B1CH11	828	785	375	700	536	410	211	50	3/8	59
B1CH13	856	875	445	700	536	410	211	50	3/8	74
B1CH17	885	990	555	700	536	410	211	50	1/2	100
B1CH20	921	1260	590	700	536	435	238	80	1/2	126
B1CH25	970	1445	725	700	536	435	238	80	1/2	172
B1CH32	1036	1900	920	700	598	540	273	125	3/4	347
B1CH40	1098	2200	1150	700	598	540	273	125	3/4	550
B1CH50	1191	2750	1390	700	621	690	296	160	1	1000
B1CH60	1191	2750	1390	700	621	690	296	160	1	1250
B1CH75	1191	2750	1390	700	621	690	296	160	1	1360

Type	Dimensions, inch								NPT	lbs
	E	F	G	L1	Nmax	Y1	Y2	X1		
B1CH11	32.60	30.90	14.80	27.56	21.10	16.14	8.31	1.97	3/8	130
B1CH13	33.70	34.50	17.50	27.56	21.10	16.14	8.31	1.97	3/8	163
B1CH17	34.84	39.00	21.90	27.56	21.10	16.14	8.31	1.97	1/2	220
B1CH20	36.26	49.60	23.20	27.56	21.10	17.13	9.37	3.15	1/2	278
B1CH25	38.19	56.90	28.50	27.56	21.10	17.13	9.37	3.15	1/2	379
B1CH32	40.79	74.80	36.20	27.56	23.54	21.26	10.75	4.92	3/4	765
B1CH40	43.23	86.60	45.30	27.56	23.54	21.26	10.75	4.92	3/4	1212
B1CH50	46.89	108.30	54.70	27.56	24.45	27.17	11.65	6.30	1	2204
B1CH60	46.89	108.30	54.70	27.56	24.45	27.17	11.65	6.30	1	2760
B1CH75	46.89	108.30	54.70	27.56	24.45	27.17	11.65	6.30	1	3000

B1JH

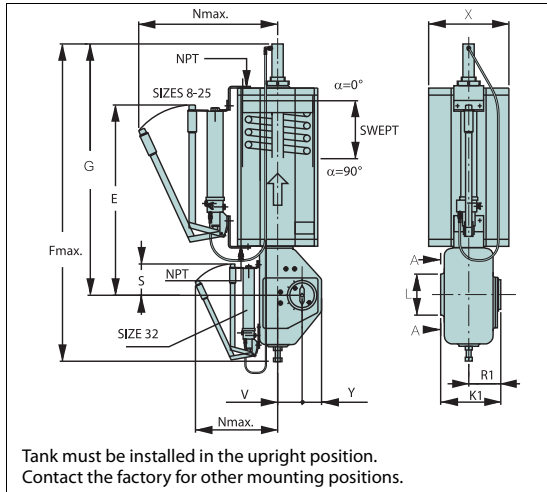

B1JH

Type	Dimensions, mm											NPT	kg
	X	G	F	E	N	V	Y	L	K1	R1	S		
B1JH8	135	585	720	517	720	43	50	80	140	81	80	3/8	30
B1JH10	175	630	790	552	740	51	50	95	154	89	80	3/8	43
B1JH12	215	745	940	623	765	65	65	120	190	109	120	1/2	70
B1JH16	265	940	1170	665	800	78	70	137	222	126	120	1/2	115
B1JH20	395	1075	1365	785	880	97	80	145	262	147	145	3/4	190
B1JH25	505	1405	1755	910	955	121	110	180	304	166	180	3/4	370
B1JH32	540	1635	2085	245	850	153	146	280	379	204	210	1	700
B1JH40	724	1906	2424	242	880	194	185	335	445	220	298	1	1125

Type	Dimensions, inch											NPT	lbs
	X	G	F	E	N	V	Y	L	K1	R1	S		
B1JH8	5.31	23.03	28.3	20.35	28.35	1.69	1.97	3.15	5.5	3.2	3.15	3/8	66
B1JH10	6.89	24.80	31.1	21.73	29.13	2.01	1.97	3.74	61	3.5	3.15	3/8	95
B1JH12	8.46	29.33	37.0	24.53	30.12	2.56	2.56	4.72	7.5	4.3	4.72	1/2	154
B1JH16	10.43	37.01	46.1	26.18	31.50	3.07	2.76	5.39	8.7	5.0	4.72	1/2	253
B1JH20	15.55	42.32	53.7	30.91	34.65	3.82	3.15	5.71	10.3	5.8	5.71	3/4	419
B1JH25	19.88	55.31	69.1	35.83	37.60	4.76	4.33	7.09	12.0	6.5	7.09	3/4	815
B1JH32	21.26	64.37	82.1	49.02	33.46	6.02	5.75	11.0	14.9	8.0	8.27	1	1543
B1JH40	28.5	75	95.4	9.5	34.6	7.6	7.3	13.2	17.5	8.7	11.7	1	2478

B1JR/B1JRR

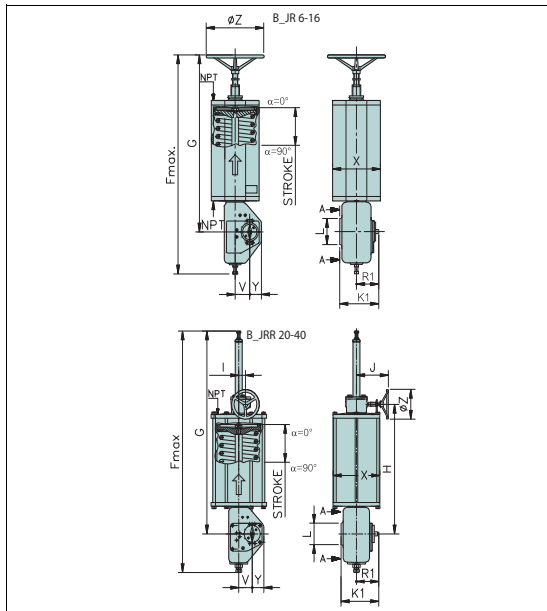

B1JR/B1JRR

Type	Dimensions, mm											NPT	kg	
	X	Z	G	F	H	I	J	V	Y	L	K1			R1
B1JR6	110	250	520	640	-	-	-	36	47	70	138	80	3/8	15.5
B1JR8	135	250	570	705	-	-	-	43	50	80	140	81	3/8	19
B1JR10	175	250	695	855	-	-	-	51	50	95	154	89	3/8	33
B1JR12	215	250	805	1000	-	-	-	65	65	120	190	109	1/2	60
B1JR16	265	400	1080	1310	-	-	-	78	70	137	222	126	1/2	106
B1JRR20	395	200	1455	1745	868	48.25	230	97	80	145	262	147	3/4	210
B1JRR25	505	250	1665	2015	1074	48.25	280	121	110	180	304	166	3/4	380
B1JRR32	540	400	1895	2345	1306	48.25	375	153	146	280	379	204	1	705
B1JRR40	724	400	2193	2710	1516	48.25	445	194	185	335	445	20	1	1130

Type	Dimensions, inch											NPT	lbs	
	X	Z	G	F	H	I	J	V	Y	L	K1			R1
B1JR6	4.33	9.84	20.47	25.20	-	-	-	1.42	1.85	2.76	5.43	3.15	3/8	34
B1JR8	5.3	9.8	22.4	27.8	-	-	-	1.7	2.0	3.1	5.5	3.2	3/8	42
B1JR10	6.9	9.8	27.4	33.7	-	-	-	2.0	2.0	3.7	6.1	3.5	3/8	73
B1JR12	8.5	9.8	31.7	39.4	-	-	-	2.6	2.6	4.7	7.5	4.3	1/2	132
B1JR16	10.4	15.7	42.5	51.6	-	-	-	3.1	2.8	5.4	8.7	5.0	1/2	233
B1JRR20	15.6	7.9	57.3	68.7	34.2	1.9	9.1	3.8	3.1	5.7	10.3	5.8	3/4	463
B1JRR25	19.9	9.8	65.6	79.3	42.3	1.9	11.0	4.8	4.3	7.1	12.0	6.5	3/4	837
B1JRR32	21.3	15.7	74.6	92.3	51.4	1.9	14.8	6.0	5.75	11.0	14.9	8.0	1	1553
B1JRR40	28.5	15.7	86.3	106.7	59.7	1.9	17.5	7.6	7.3	13.2	17.5	8.7	1	2489

B1JAR/B1JARR

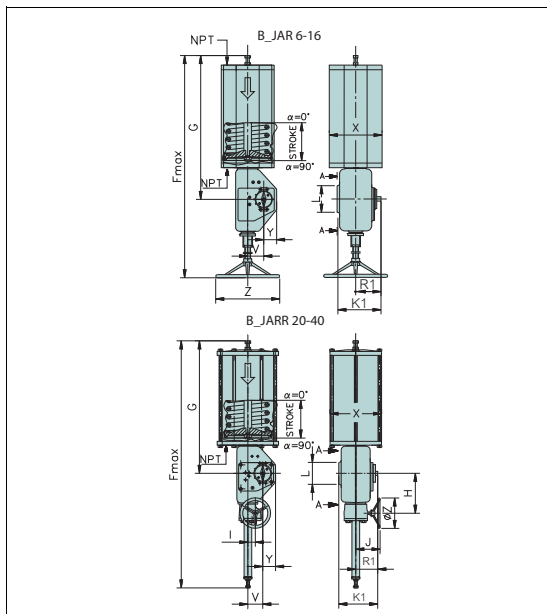

B1JAR/B1JARR

Type	Dimensions, mm											NPT	kg	
	X	Z	G	F	H	I	J	V	Y	L	K1			R1
B1JAR6	110	250	367	655	-	-	-	36	47	70	138	80	3/8	15.5
B1JAR8	135	250	420	720	-	-	-	43	50	80	140	81	3/8	20
B1JAR10	175	250	480	870	-	-	-	51	50	95	154	89	3/8	30
B1JAR12	215	250	620	1030	-	-	-	65	65	120	190	109	1/2	55
B1JAR16	265	400	760	1345	-	-	-	78	70	137	222	126	1/2	100
B1JARR20	395	250	940	1785	285	48.25	175	97	80	145	262	147	3/4	210
B1JARR25	505	250	1140	2025	314	48.25	185	121	110	180	304	166	3/4	380
B1JARR32	540	400	1435	2385	381	48.25	240	153	146	280	379	204	1	705
B1JARR40	724	400	1578	2748	443	48.25	294	194	185	335	445	220	1	1130

Type	Dimensions, inch											NPT	lbs	
	X	Z	G	F	H	I	J	V	Y	L	K1			R1
B1JAR6	4.33	9.84	14.45	25.79	-	-	-	1.42	1.85	2.76	5.43	3.15	3/8	34
B1JAR8	5.3	9.8	16.5	28.3	-	-	-	1.7	2.0	3.1	5.5	3.2	3/8	44
B1JAR10	6.9	9.8	18.9	34.3	-	-	-	2.0	2.0	3.7	6.1	3.5	3/8	66
B1JAR12	8.5	9.8	24.4	40.6	-	-	-	2.6	2.6	4.7	7.5	4.3	1/2	121
B1JAR16	10.4	15.7	29.9	53.0	-	-	-	3.1	2.8	5.4	8.7	5.0	1/2	220
B1JARR20	15.6	9.8	37.0	70.3	11.2	1.9	6.9	3.8	3.1	5.7	10.3	5.8	3/4	463
B1JARR25	19.9	9.8	44.9	79.7	12.4	1.9	7.3	4.8	4.3	7.1	12.0	6.5	3/4	837
B1JARR32	21.3	15.7	56.5	93.9	15.0	1.9	9.4	6.0	5.75	11.0	14.9	8.0	1	1553
B1JARR40	28.5	15.7	62.1	108.2	17.4	1.9	11.6	7.6	7.3	13.2	17.5	8.7	1	2489

MOUNTING FACE DIMENSIONS

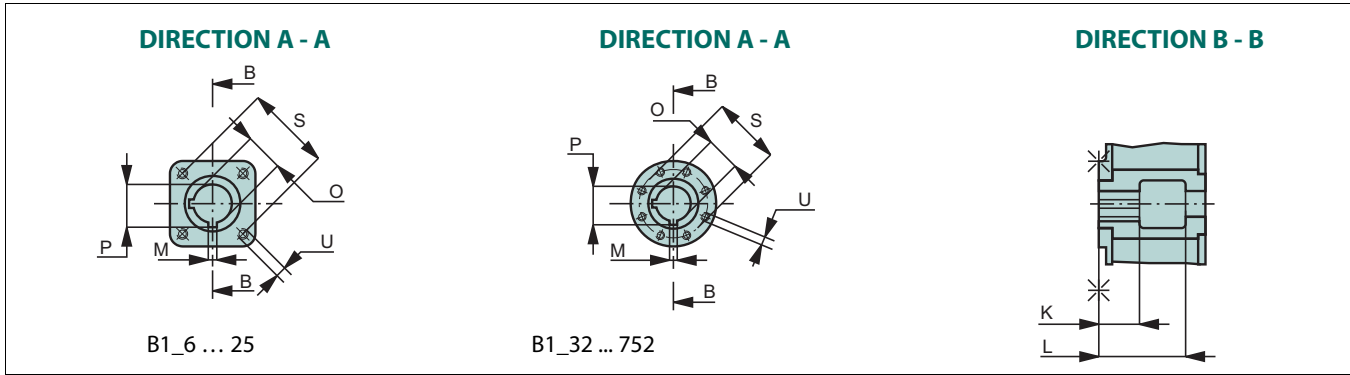

Actuator		Dimensions, mm										Mounting face
B1C	B1J	O (F8)	M	P	K (keyway)	L	S	U	N	Thread length		
6	6	15 20 25	4.76 4.76 6.35"	17.0 23.3 27.9	40	90	70	M8	4	16	F07	
9	8	15 20 25 35	4.76 4.76 6.35 9.52	17.0 23.3 27.9 39.3	50	90	70	M8	4	19	F07	
11	10	20 25 35 40	4.76 6.35 9.52 9.52	23.3 27.9 39.3 44.4	60	105	102	M10	4	19	F10	
13	12	55	12.70	60.8	75	130	125	M12	4	26	F12	
17	16	55	12.70	60.8	80	120	140	M16	4	16	F14	
20	20	70	19.05	78.3	105	195	140	M16	4	30	F14	
25	25	95	22.22	105.5	140	235	165	M20	4	35	F16	
32	32	105	25.40	116.3	155	280	254	M16	8	40	F25	
40	40	95 105 120	22.22 25.40 31.75	105.5 116.3 133.9	180	340	298	M20	8	54	F30	
50 60 75		120 135	31.75 31.75	133.9 149.2	200	430	356	M30	8	54	F35	
	322	95 105 120	22.22 25.40 31.75	105.5 116.3 133.9	180	320	298	M20	8	65	F30	
502 602 752		120 135 150 165 180	31.75 31.75 38.10 38.10 44.45	133.9 149.2 166.8 182.0 199.4	250	470	406	M36	8	70	F40	

Actuator		Dimensions, inch										Mounting face
B1C	B1J	O (F8)	M	P	K (keyway)	L	S	U	N (pcs.)	Thread length		
6	6	0.59 0.79 0.98	0.19 0.19 0.25	0.67 0.92 1.10	1.57	3.54	2.76	M8	4	0.62	F07	
9	8	0.59 0.79 0.98 1.38	0.19 0.19 0.25 0.37	0.67 0.92 1.10 1.55	1.97	3.54	2.76	M8	4	0.74	F07	
11	10	0.79 0.98 1.38 1.57	0.19 0.25 0.37 0.37	0.92 1.10 1.55 1.75	2.36	4.13	4.02	M10	4	0.74	F10	
13	12	2.17	0.50	2.39	2.95	5.12	4.92	M12	4	1.02	F12	
17	16	2.17	0.50	2.39	3.15	4.72	5.51	M16	4	1.02	F14	
20	20	2.76	0.75	3.08	4.13	7.68	5.51	M16	4	1.18	F14	
25	25	3.74	0.87	4.15	5.51	9.25	6.50	M20	4	1.38	F16	
32	32	4.13	1.00	4.58	6.10	11.02	10.00	M16	8	1.57	F25	
40	40	3.74 4.13 4.72	0.87 1.00 1.25	4.15 4.58 5.27	7.09	13.39	11.73	M20	8	2.13	F30	
50 60 75		4.72 5.31	1.25 1.25	5.27 5.87	7.87	16.93	14.02	M30	8	2.13	F35	
	322	3.74 4.13 4.72	0.87 1.00 1.25	4.15 4.58 5.27	7.09	12.60	11.73	M20	8	2.56	F30	
502 602 752		4.72 5.31 5.91 6.50 7.09	1.25 1.25 1.50 1.50 1.75	5.27 5.87 6.57 7.17 7.85	9.84	18.50	15.98	M36	8	2.76	F40	

ACCESSORIES MOUNTING FACE DIMENSIONS

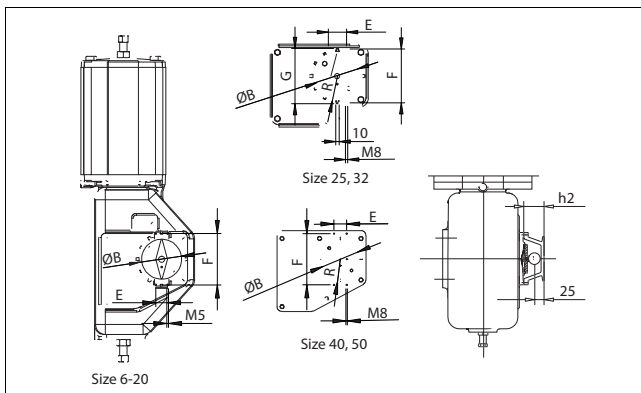

Actuator size	E	F	h2	B	R
6	30	80	45	45	-
8, 9	30	80	45	55	-
10, 11	30	80	45	60	-
12, 13	30	130	55	80	-
16, 17	30	130	55	80	-
20	30	130	55	100	-
25	54	160	55	130	83
32	54	188	55	150	96
40	64	260	55	190	115
50	64	290	55	210	130

HOW TO ORDER

Pneumatic double-acting cylinder actuator, Series B1C

1.	2.	3.	4.	5.	6.	7.	8.	9.	10.	11.
B1	C	-	S	Y	U	50/120	HL	E	X	M

Signs 1, 2, 6 and 7 are obligatory: other marks are options

1. sign	PRODUCT GROUP
B1	Cylinder actuator with attachment dimensions acc. to ISO 5211.

2. sign	SERIES
C	Double acting, pneumatic, protection class IP66.

3. sign	CONSTRUCTIONS
-	Standard construction without sign.
H	Manual hydraulic override.

4. sign	CYLINDER AND HOUSING MATERIALS
-	Aluminium cylinder and EN 1561-GJL-200 housing, standard materials, without sign. Except if sign 8. is arctic version "A" then housing and piston always EN 1563-GJS-400-15.
S	Steel cylinder and EN 1561-GJL-200 housing and piston. Except if sign 8. is arctic version "A" then housing and piston always EN 1563-GJS-400-15. (Not available with size 6).
B	Aluminium cylinder and EN 1563-GJS-400-15 housing and piston. (Not available with size 6).
X	Steel cylinder and EN 1563-GJS-400-15 housing and piston. (Not available with size 6).

5. sign	SPECIAL CONSTRUCTION
-	Standard construction without sign
Q	Mechanical locking device for piston movement limit on housing end. Locking with long screw to <u>close</u> position.
W	Mechanical locking device for piston movement limit on cylinder end. Locking with long screw to <u>open</u> position.
QW	Mechanical locking device for piston movement limit on housing and cylinder ends. Locking with long screws to close as well as to open position.
Z	Actuator equipped with shock absorber on cylinder end, (-20 ... +120 °C)
N	Actuator equipped with shock absorber on housing end, (-20 ... +120 °C)
P	Actuator equipped with automatic latching device for closed position. Design is made mainly for actuator locking device of capping valve. No free motion.
T	Actuator equipped with manual latching device. Actuator can be locked to <u>open</u> position allowing about 20 degrees' motion.
K	Handwheel on cylinder end (sizes 9 to 25).
L	Handwheel on housing end (sizes 9 to 25).
R	Handwheel both on cylinder end and housing end (sizes 9 to 25).
RK	Handwheel on cylinder end with wormgear (sizes 32 - 75). Not used in 502, 602 and 752.
RL	Handwheel on housing end with wormgear (sizes 32 - 75). Not used in 502, 602 and 752.
RR	Handwheel both on cylinder end and housing end with wormgear (sizes 32 - 75). Not used in 502, 602 and 752.
Y	Special, to be specified, e.g. special material or stop screw.

6. sign	INTERFACE FOR ADDITIONAL DEVICES (positioner, limit switch)
U	Interface engineered to VDI/VDE with the use of Metso linkages.

7. sign	ACTUATOR SIZE
	E.g. 50/ 120 = actuator size / shaft bore diameter. Note special sizes (BC 50 and 502 with oversized cylinder): 60 - max. operating pressure 8.5 bar (cylinder Ø 600 mm/24") 75 - max. operating pressure 5 bar (cylinder Ø 750 mm/30") 602 - max. operating pressure 8.5 bar (cylinder Ø 600 mm/24") 752 - max. operating pressure 5 bar (cylinder Ø 750 mm/30")

8. sign	MATERIALS OF SEALS AND BEARINGS (all versions ATEX II 2 G c and ATEX II 3 G c)
-	Standard construction without sign (-20° to +70 °C).
HL	For temperatures -20 ... +120 °C and long-run option L .
CL	For temperatures -40 ... +70 °C, and long-run option L.
C	For temperatures -40 ... +70 °C.
A	For temperatures -55 ... +70 °C, Arctic service model. Not available if 3. sign "H" or 11. sign "M". Size 6 not available.
F	Oversized NPT connections: fast operation.
F1	Large oversized NPT connections: faster operation.
S	Super long-run option. (-20 ... +70 °C)
L	Long-run option .
D	DU-bearings - for sizes 32...502. Note: Not applicable with L, CL and HL options

9. sign	SCREW MATERIAL
-	Stainless steel (standard) without sign for sizes 6 through 32 Steel, zinc coated and passivated (standard) without sign for sizes 40 and bigger.
E	With aluminium cylinder screw material stainless steel for sizes 25 and bigger. With steel cylinder screw material stainless steel for all sizes.

10. sign	NON-STANDARD OPERATION RANGE e.g. 30° - 70° (standard operation range e.g. for ball valves 0° - 90°, without sign)
X	Valve closed position is limited. When closed position is limited to 30°, X = 30 (never fully closed).
Z	Valve open position is limited. When open position is limited to 70°, Z = 70 (never fully open).

11. sign	SPECIAL CONSTRUCTION
6	Protection class IP66M
7	Protection class IP67/IP67M
G	Oxygen service model
M	K-mass fire protection.
T	Tropicalization

Pneumatic, single-acting cylinder actuator, Series, B1J and B1JA

1.	2.	3.	4.	5.	6.	7.	8.	9.	10.	11.	12.	13.
B1	J	K	A	R	S	Y	U	20/70	HL	E	Z	M

Signs 1, 2, 8 and 9 are obligatory, other signs are options

1. sign	PRODUCT GROUP
B1	Cylinder actuator with attachment dimensions acc. to ISO 5211.

2. sign	SERIES
J	Pneumatic, spring-return, protection class IP66.

3. sign	SPRING OPTIONS
-	Standard construction without sign.
K	Light spring.
V	Strong spring.

4. sign	FUNCTION CODE
-	Spring-to-close operation, without sign.
A	Spring-to-open operation.

5. sign	CONSTRUCTION
-	Standard construction without sign.
R	Secondary handwheel operation (sizes 6 - 16).
RR	Secondary handwheel with wormgear (sizes 20 - 40).
H	Manual hydraulic override. Not available with B1J(A)6.

6. sign	CYLINDER AND HOUSING MATERIALS
-	Aluminium cylinder and EN 1561-GJL-200 housing, standard materials without sign. Except if sign 10. is arctic version "A" then housing and piston always EN 1563-GJS-400-15.
S	Steel cylinder and EN 1561-GJL-200 housing and piston. Except if sign 10. is arctic version "A" then housing and piston always EN 1563-GJS-400-15.
B	Aluminum cylinder and EN 1563-GJS-400-15 and piston. When 10. sign is "A", without sign, standard material.
X	Steel cylinder and EN 1563-GJS-400-15 and piston.

7. sign	SPECIAL CONSTRUCTION
-	Standard construction without sign.
Q	Mechanical locking device for piston movement limit on housing end. Locking with long screw to <u>close</u> position.
W	Mechanical locking device for piston movement limit on cylinder end. Locking with long screw to <u>open</u> position.
Z	Actuator equipped with shock absorber on cylinder end, (-20 ... +120 °C).
N	Actuator equipped with shock absorber on housing end, (-20 ... +120 °C).
QW	Mechanical locking device for piston movement limit on housing and cylinder ends. Locking with long screws to close as well as to open position.
T	Actuator equipped with manual latching device. The actuator can be locked in series B1J for open position and in series B1JA for closed position allowing about 20 degrees' motion. Not available with B1J(A)6.
Y	Special, to be specified e.g. special material or stop screw.

8. sign	INTERFACE FOR ADDITIONAL DEVICES (positioner, limit switch)
U	Interface engineered to VDI/VDE with the use of Metso linkages.

9. sign	ACTUATOR SIZE
-	6/15 6/20 6/25 - 8/15 8/20 8/25 8/35 - 10/20 10/25 10/35 10/40 - 12/55 - 16/55 - 20/70 25/95 - 32/105 - 40/95 40/105 40/120 - 322/95 322/105 322/120 E.g. 20 / 70 = actuator size / shaft bore diameter

10. sign	MATERIALS OF SEALS AND BEARINGS (all versions ATEX II 2 G c and ATEX II 3 G c)
-	Standard construction without sign (-20° to +70 °C).
HL	For temperatures -20 ... +120 °C and long-run option L.
CL	For temperatures -40 ... +70 °C, and long-run option L.
C	For temperatures -40 ... +70 °C.
A	For temperatures -55 ... +70 °C, Arctic service model. Not available if 5. sign "H" or 13. sign "M".
F	Oversized NPT connections: fast operation. Not available with B1J(A)6
F1	Large oversized NPT connections: faster operation. Not available with B1J(A)6
F2	Largest oversize NPT connections: fastest operation. Not available with B1J(A)6
S	Super long-run option. (-20 ... +70 °C)
L	Long-run option
D	DU-bearings - for sizes 32...322. Note: Not applicable with L, CL and HL options.

11. sign	SCREW MATERIAL
-	Stainless steel (standard) with out sign for sizes 6 through 20 Steel zinc coated and passivated (standard) without sign for sizes 25 and bigger.
E	Stainless steel for sizes 25 and bigger.

12. sign	NON-STANDARD OPERATION RANGE e.g. 30° - 70° standard operation range e.g. for ball valves 0° - 90°, without sig
X	Valve closed position is limited. When closed position is limited to 30°, X = 30 (never fully closed).
Z	Valve open position is limited. When open position is limited to 70°, Z = 70 (never fully open).

13. sign	SPECIAL CONSTRUCTION
6	Protection class IP66M
7	Protection class IP67/IP67M
G	Oxygen service model
M	K-mass fire protection.
T	Tropicalization

Metso Corporation

Töölönlahdenkatu 2, PO Box 1220, 00100 Helsinki, Finland
Tel. +358 20 484 100

Metso Flow Control Inc.

Vanha Porvoontie 229, P.O. Box 304, FI-01301 VANTAA, Finland.
Tel. +358 20 483 150. Fax +358 20 483 151

www.metso.com/valves

Subject to change without prior notice. Product names in this bulletin are all trademarks of Metso Flow Control Inc.

